

Instructions for 2 Step Metal Floor Stand & 3 Step Metal Floor Stand

Picture shown is for the 3-Step Metal Floor Stand

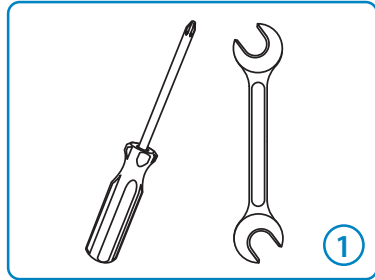

1 You will need a screwdriver (cross-head) and a wrench.

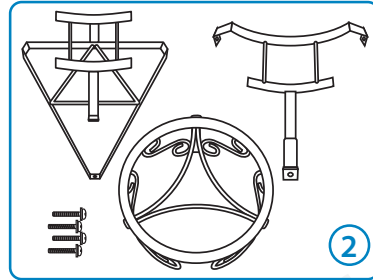

2 Collect all screws, cap fasteners, and parts together. Top Bracket, Mid Bracket, Bottom Bracket

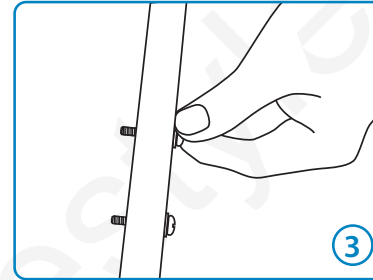

3 Start with 1 of the 3 metal legs. Insert 2 screws into the hole. This will be the top section of the leg and connected to top bracket.

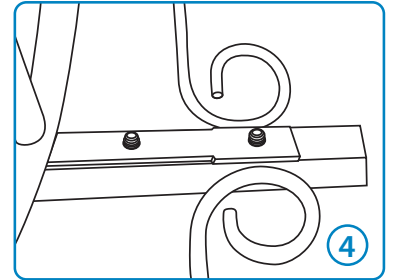

4 Fasten the leg to the top bracket of the stand as shown. Use set of screw, washer and fastener.

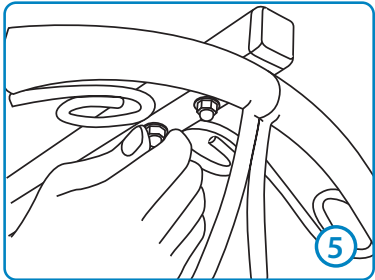

5 Do not fasten too tightly to ensure proportion of the whole stand first.

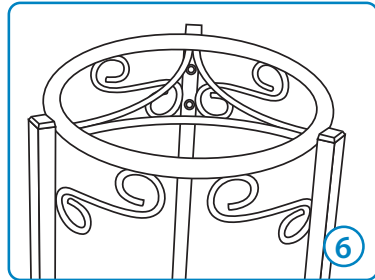

6 After you have attached the first leg to the top bracket, repeat process until all legs are attached.

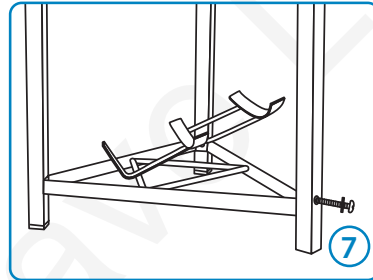

7 After all legs are attached to the top bracket, start to attach the bottom bracket.

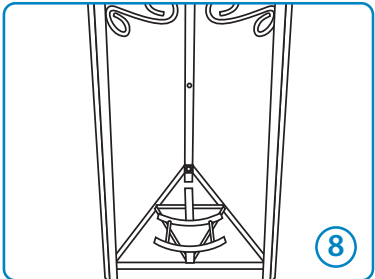

8 Once the bottom bracket has been attached, you can move onto mid-bracket. (For the 2 Step Stand, you are complete.)

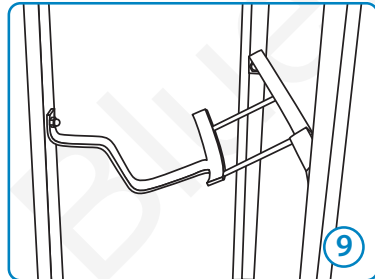

9 For the 3 step stand, Take the mid-bracket and start to attach to the metal stand.

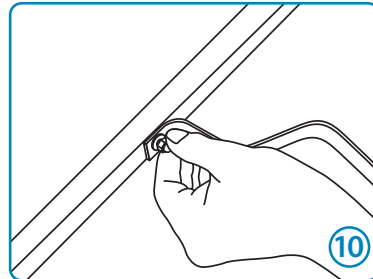

10 After you have attached all brackets, tighten all the screws and fasteners to make the stand sturdy and steady.

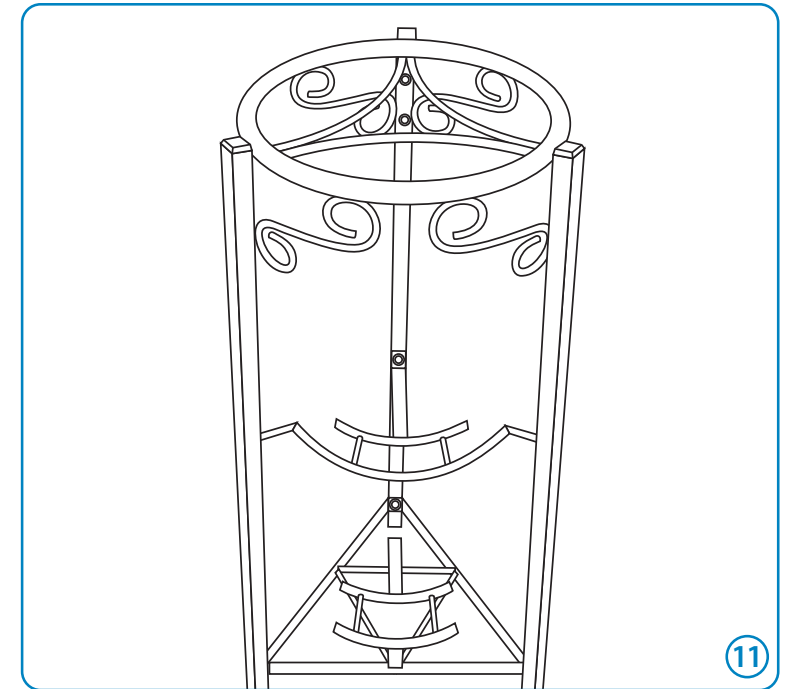

11 Once you have correctly assemble the stand, the stand is ready for use. The stand can hold a full dispenser on the top and provides additional bottle storage on the bottom.